

VEIKAI
上海维凯



VK4-12P户内高压真空断路器

Indoor High-voltage Vacuum Circuit Breaker



上海维凯电气有限公司
SHANGHAI VEIKAI ELECTRIC CO. LTD.



欲知详情，请访问官方网站

VK4 系列

户内高压真空断路器

Indoor High-voltage Vacuum Circuit Breaker



户内高压真空断路器

Indoor High-voltage Vacuum Circuit Breaker

- 开关设备只能安装于适合电气设备工作的户内场所。
 - 确保由专业人员来进行安装、操作和维护。
 - 必须保证现场电气设备的连接及工作规程的适用性与安全性。
 - 有关开关设备的一切操作，都应遵守本说明书中的相应规定。
 - **⚠ 危险!**
请特别注意说明书中标有这个危险标志的注意事项。
 - 不要超出开关设备在正常工作条件下的技术参数中规定的负载。
 - 说明书应放在所有与安装、操作及维护有关的人员便于拿到的地方。
 - 用户的专职人员应对所有影响工作安全的事项负责，并正确使用开关设备。
 - 若对本说明书尚有任何疑问，我们很乐意为您提供进一步的资讯。
- This switchgear should be only installed indoors where is suitable for electrical equipment.
 - The installation, operation and maintenance should be done by the professionals.
 - Must guarantee the connection reliability of on-site electrical equipment as well as the applicability and safety of operation rules.
 - All operations to switchgear should conform to relevant regulations in this manual.
 - **⚠ Danger!**
Please pay special attention to the precautions with this mark.
 - Don't use loads that beyond the specified technical parameters under normal operating conditions.
 - The manual should be put in visible place where the operator and maintenance personnel can get it easily.
 - The operator should be responsible for all safety operations, and should use the switchgear properly.
 - Feel free to contact us if any question, we are pleasure to provide further information.

型号的表达式 / Model description

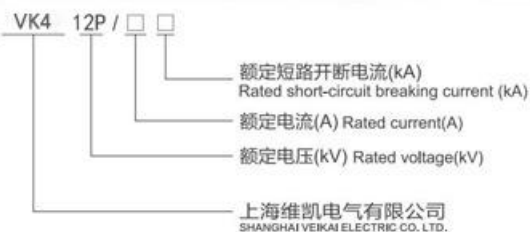



产品概述 / Overview

VK4 型户内高压真空断路器 (以下简称断路器) 是用于12KV电力系统的户内开关设备, 作为电网设备, 工矿企业动力设备的保护和控制单元。由于真空断路器的特殊优越性, 尤其适用于要求额定工作电流的频繁操作, 或多次开断短路电流的场所。断路器采用操动机构与断路器本体一体式设计, 既可做为固定安装单元, 也可配用专用推进机构, 组成手车单元使用, 其中固定式断路器可以增加相应的联锁, 以满足配XGN2、GG1A等固定柜的需要。

VK4 indoor high-voltage vacuum circuit breaker (hereinafter referred to as circuit breaker) is an indoor switching device for power systems of 12KV, used as protection and control unit for power grid equipment and electrical equipment in industrial and mining enterprises. Due to its special advantages, it is quite suitable for locations where need frequent operation at rated working current, or need frequent short-circuit current breaking operation. The circuit breaker adopts integrated design of operating mechanism and body of circuit breaker, it not only can be used as a fixed installation unit, but also can be equipped with a special propelling mechanism to constitute a handcart unit for operation. The fixed type circuit breaker also can be equipped with corresponding interlocks to meet the needs of XGN2, GG1A and other fixed type switchgears.

产品依据标准 / Normative references

断路器符合GB1984-89《交流高压断路器》、JB3855-1996《3.6-40.5kV户内交流高压真空断路器》, DL/T403-2000《12kV-40.5kV高压真空断路器订货技术条件》标准要求, 并符合IEC56(87出版物)的相关要求。

The circuit breaker complies with the standards GB1984-89 Alternating current high-voltage circuit-breakers, JB3855-1996 Indoor high-voltage alternating-current vacuum circuit breaker of 3,6~40,5kV, DL/T403-2000 HV vacuum circuit-breaker for rated voltage 12kV to 40,5kV, also is in conformity with relevant requirements of IEC56 (87 edition).

使用环境条件 / Service conditions

- 环境温度
最高温度: +40℃
最低温度: -15℃
- 环境湿度
日平均相对湿度: ≤95%
月平均相对湿度: ≤90%
日平均蒸气压: ≤2.2×10⁻³ MPa
月平均蒸气压: ≤1.8×10⁻³ MPa
- 海拔高度: 不超过1000m;
- 地震烈度不超过8度;
- 使用场所无滴水, 无易燃和爆炸危险, 无化学腐蚀性气体以及无剧烈震动。
- Ambient temperature
Maximum: +40℃
Minimum: -15℃
- Ambient humidity
Daily mean relative humidity: ≤95%
Monthly mean relative humidity: ≤90%
Daily mean vapor pressure: ≤2.2×10⁻³ MPa
Monthly mean vapor pressure: ≤1.8×10⁻³ MPa
- Altitude: not exceed 1000m;
- Seismic intensity: not exceed Ms8;
- Locations free of water drop, far away from flammable or explosive danger, no chemical or corrosive gas or severe vibration.

主要规格及技术参数 / Main specifications and technical parameters

主要规格及技术参数见表1
See table 1 for main specifications and technical parameters

序号 No.	单位 Unit	数值 Data
1 额定电压 / Rated voltage		12
2 额定短时工频耐受电压(1min) Rated short-time power frequency withstand voltage (1min)	kV	42
3 额定雷电冲击耐受电压(峰值) Rated lightning impulse withstand voltage (peak)		75
4 额定频率 / Rated frequency	Hz	50
5 额定电流 / Rated current	A	630 1250 630 1250 630 1250 1600 2000 2500 3150 1250 1600 2000 2500 3150 4000* 1600 2000 2500 3150 4000*
6 额定短路开断电流 / Rated short-circuit breaking current	kA	20 25 31.5 40 50
7 额定短时耐受电流 / Rated short-time withstand current		20 25 31.5 40 50
8 额定短路持续时间 / Rated short-circuit duration	s	4
9 额定峰值耐受电流 / Rated peak withstand current	kA	50 63 80 100 125
10 额定短路关合电流 / Rated short-circuit making current		50 63 80 100 125
11 二次回路工频耐受电压(1min) Power frequency withstand voltage of secondary circuit (1min)	V	200
12 额定单个/背对背电容器组开断电流 Rated breaking current of single / back-to-back capacitor bank	A	630/400(40kA为800/400) / 630/400(that of 40kA is 800/400)
13 额定电容器组关合涌流 Rated capacitor bank inrush making current	kA	12.5(频率不大于1000Hz) / 12.5(frequency not more than 1000Hz)
14 分闸时间(额定电压) / Opening time (rated voltage)	ms	20~50
15 合闸时间(额定电压) / Closing time (rated voltage)		35~70
16 机械寿命 / Mechanical life		20000(50kA为10000次) / 20000(that of 50kA is 10000 times)
17 额定电流开断次数(电寿命) Rated current breaking times (electrical life)	次 / Times	20000(50kA为10000次) / 20000(that of 50kA is 10000 times)
18 额定短路电流开断次数 Rated short-circuit current breaking times		50(40kA为30、50kA为20) / 50(that of 40kA is 30, 50kA is 20)
19 动、静触头允许磨损累计厚度 Permissible wear thickness of moving and static contacts	mm	3
20 额定合闸操作电压 / Rated closing operating voltage	v	AC110/220 DC110/220
21 额定分闸操作电压 / Rated opening operating voltage		AC110/220 DC110/220
22 储能电机额定电压 / Rated voltage of energy-storage motor	v	AC110/220 DC110/220
23 储能电机额定功率 / Rated power of energy-storage motor	w	80
24 储能时间 / Energy-storage time	s	≤15
25 触头开距 / Clearance between open contacts	mm	10±1
26 超行程 / Overtravel		3.5±0.5
27 触头合闸弹跳时间 / Contact closing bounce time	ms	≤2(40kA≤3)
28 三相分、合闸不同期性 Three-phase opening and closing asynchrony		≤2
29 平均分闸速度(触头分开~6mm) Average opening speed (contact opening~6mm)	m/s	0.9~1.2
30 平均合闸速度(6mm-触头闭合) Average closing speed (6mm-contact closing)		0.5~0.8
31 触头分闸反弹幅值 / Contact opening rebound value	mm	≤3
32 主导电回路电阻 / Resistance of main conductive circuit	uΩ	≤50(630A) ≤45(1250A) ≤35(1600~2000A)≤25(2500A)以上)
33 触头合闸接触压力 / Contacting pressure of contact closing	N	2400±200(20kA、25kA) 3100±200(31.5kA) 4250±250(40kA) 7000±250(50kA)
34 额定操作顺序 / Rated operation sequence		分-0.3s-合分-180s-合分 / O-0.3s-CO-180s-CO 分-180s-合分-180s-合分(50kA) / O-180s-CO-180s-CO (50kA)

注：4000A需强制风冷 Note: that of 4000A needs forced air cooling system



产品结构及工作原理 /Product structure and working principle

主体结构 /Structure of main body

断路器主体部分设置在由环氧树脂采用APG工艺浇注而成的绝缘筒内，这种结构能有效地防止包括外力冲击、污秽环境等外部因素对真空灭弧室的影响。断路器主体安装在断路器框架后部，与操动机构连接一个整体。

Main body of circuit breaker is set in an insulating cylinder that is made of epoxy resin by means of APG casting, which protects the vacuum arc-extinguish chamber from impact of external forces, polluted environment, or other external factors. The main body of breaker is installed at the back of framework, forms into one-piece with the operating mechanism.

断路器在合闸位置时主回路电流路径：(参见图2)

Current path of main loop of circuit breaker in closing position: (see Fig.2)

上出线座27经固定在灭弧室上的上支架26到真空灭弧室内部静触头，经动触头及与其联接的导电夹、软连接，至下支架30到下出线座31。

断路器出厂时各电流等级均装有防尘绝缘筒盖，在实际使用中，额定电流1250A及以下等级运行时可不必去除，额定电流1600A及以上等级运行时必须去除。

From upper outlet 27, pass the upper support 26 that is fixed on the arc-extinguish chamber, flow through the static contact inside the vacuum arc-extinguish chamber, to lower support 30 by moving contact and conductive clamp and flexible coupling that are connected with the moving contact, reach the lower outlet 31.

When leaving the factory, circuit breakers of each current class are equipped with dustproof insulating cylinder cover, which can be remained when the breakers of rated current up to and including 1250A is put into operation, but must be removed for that of rated current of 1600A and above.

操动机构(参见图1、图2) /Operating mechanism (see Fig.1 and 2)

操动机构为弹簧储能操作机构，断路器框架内装有合闸单元，由一个或数个脱扣电磁铁组成的分闸单元，辅助开关，指示装置等部件；前方设有合、分按钮，手动储能操作孔，弹簧储能状态指示牌，合分指示牌等。

It adopts spring energy-storage operating mechanism, with closing unit, opening unit that is composed of one or multi tripping electromagnets, auxiliary switch, indicator and other components inside the framework of circuit breaker; there are ON/OFF button, manual storing operating hole, spring storing status indicator, ON/OFF indicator and so on in the front.

a. 储能 /Energy storage

断路器合闸所需能量由合闸弹簧储能提供。储能既可由外部电源驱动电机完成，也可以使用储能手柄手动完成。

Energy required by closing of circuit breaker is provided by energy storing of closing spring. The energy storage can be finished either by external power supply by means of motor driving, or by energy-storage handle by manual.

储能操作：由固定在框架上的储能电机16进行，或者将储能手柄插入手动储能孔中逆时针摇动进行。电动储能时由电机输出轴15带动链轮转动系统(14, 23, 18)，手动储能时通过蜗轮、蜗杆(11, 13)带动链轮传动系统。链轮13转动时，销2推动轮6上的滑块4使储能轴7跟随转动并通过拐臂5和21拉伸合闸弹簧进行储能。到达储能位置时，框架上的限位杆3压下滑块4使储能轴与链轮传动系统脱开，储能保持掣子9顶住滚轮8保持储能位置，同时储能轴上连板24带动储能指示牌25翻转显示“已储能”标记并切换辅助开关切断储能电机供电电源，此时断路器处于合闸准备状态。

Energy storing: it can be done by energy-storage motor 16 that is fixed on the framework, or by inserting the energy-storage handle into manual storing hole and rotating CCW. When adopting motor storage, the motor output shaft 15 drives sprocket driving system (14, 23, 18); or the worm wheel and worm (11, 13) drive the sprocket driving system if adopted manual storage. When the sprocket wheel 13 rotates, pin 2 pushes the sliding block 4 on the wheel 6 and let the energy-storage shaft 7 rotate along with the wheel, and the crank arms 5 and 21 elongate the closing spring to store energy. When reaching the designated position, the gag lever post 3 on the framework presses down the sliding block 4 to separate the energy-storage shaft from the sprocket driving system, meanwhile, energy-storage retaining detent 9 presses against the idler wheel 8 and retains the storing position, connecting plate 24 on the energy-storage shaft drives the energy-storage indicator to turn to display the mark of energy stored, meanwhile, change over the auxiliary switch to cut off the power supply of energy-storage motor, now the circuit breaker is in ready state of closing.

b. 合闸 /Closing

断路器合闸所需能量由合闸弹簧储能提供。储能既可由外部电源驱动电机完成，也可以使用储能手柄手动完成。

Energy required by closing of circuit breaker is provided by energy storing of closing spring. The energy storage can be finished either by external power supply by means of motor driving, or by energy-storage handle by manual.

在合闸操作中，不论用手按下“合闸”按钮或远方操作使合闸电磁铁动作，均可使储能保持轴19转动，使掣子9松开滚轮8，合闸弹簧收缩同时通过拐臂5、21使储能轴7和轴上的凸轮22转动，凸轮驱动连杆机构(34、36、37、38、39)带动绝缘拉杆33和动触头进入合闸位置，并压缩触头弹簧32，保持触头所需接触压力。合闸动作完成后合闸保持掣子38与半轴41保持合闸位置，同时储能指示牌、储能辅助开关复位电机供电回路接通。

若外接电源也接通则再次进入储能状态，连杆44拉动合/分指示牌，显示出“合”的标记，转动连杆拉动主辅助开关切换。

In closing operation, the energy-storage retaining shaft 19 can be rotated either by pressing the Closing Button or by closing electromagnet by remote operation to separate the detent 9 from idler wheel 8, at the same time of compression of closing spring, to drive the energy-storage shaft 7 and the cam 22 on it by means of crank arms 5 and 21, the cam drives the link mechanism (34, 36, 37, 38, 39) to bring the insulating pull rod 33 and moving contact into closing position and compress the contact spring 32 to keep a necessary contacting pressure for contacts. After the closing operation, the closing detent 38 and haft-shaft 41 retain the closing position. Meanwhile, the energy-storage indicator and energy storing auxiliary switch restore, power supply circuit of motor is put through, it would enter into energy-storage state again if the external power supply is switched on once more. The connecting rod 44 pulls the ON/OFF indicator to display "ON", and the driving rod actuates the main and auxiliary switches to switch over.



图1/ Fig.1

- | | |
|---|---|
| 1、储能到位切换用微动开关
Sensitive switch for changeover at energy fully stored | 13、手动储能传动蜗轮
Manual energy-storage driving worm wheel |
| 2、销 / Pin | 14、电机传动链轮 / Motor driving sprocket |
| 3、限位杆 / Gag lever post | 15、电机输出轴 / Motor output shaft |
| 4、滑块 / Sliding block | 16、储能电机 / Energy-storage motor |
| 5、拐臂 / Crank arm | 17、联锁传动弯板 / Interlocking driving bending plate |
| 6、储能传动轮 / Energy-storage driving wheel | 18、传动链条 / Driving chain |
| 7、储能轴 / Energy-storage shaft | 19、储能保持轴 / Energy-storage retaining shaft |
| 8、滚轮 / Idler wheel | 20、闭锁电磁铁 / Latching electromagnet |
| 9、储能保持掣子 / Energy-storage retaining detent | 21、拐臂 / Crank arm |
| 10、合闸弹簧 / Closing spring | 22、凸轮 / Cam |
| 11、手动储能蜗杆 / Manual energy-storage worm | 23、储能传动链轮 / Energy-storage driving sprocket |
| 12、合闸电磁铁 / Closing electromagnet | 24、连板 / Connecting plate |
| | 25、储能指示牌 / Energy-storage indicator |

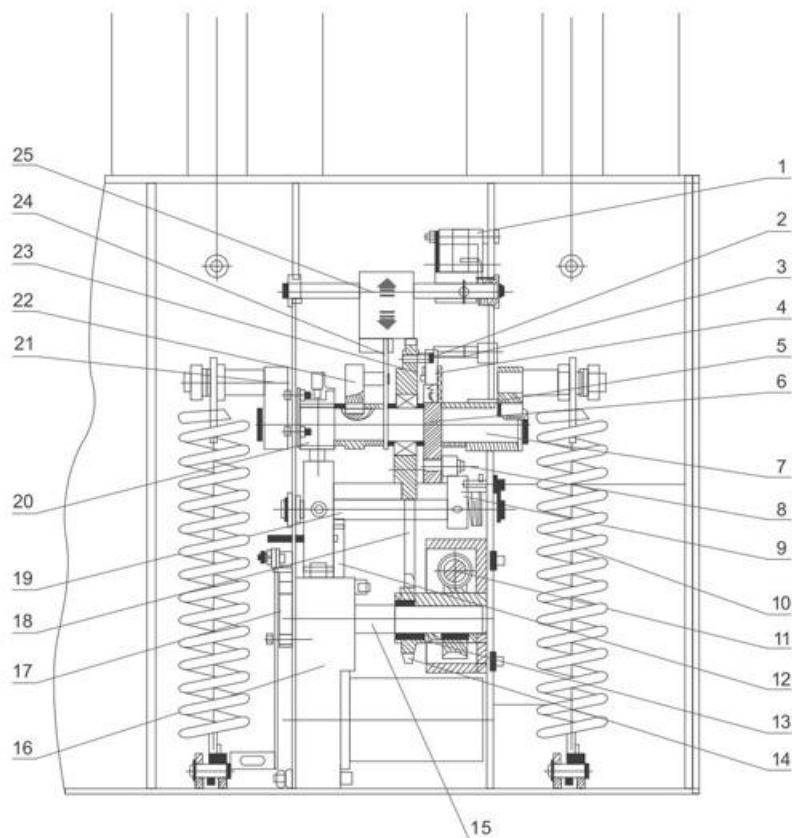

图2/ Fig.2

- | | |
|--|---|
| 26、上支架 / Upper support | 35、分闸弹簧 / Opening spring |
| 27、上出线座 / Upper outlet | 36、传动连板 / Driving connecting plate |
| 28、真空灭弧室 / Vacuum arc-extinguish chamber | 37、主轴传动拐臂 / Driving crank arm of main shaft |
| 29、绝缘筒 / Insulating cylinder | 38、合闸保持掣子 / Closing retaining detent |
| 30、下支架 / Lower support | 39、连板 / Connecting plate |
| 31、下出线座 / Lower outlet | 40、分闸电磁铁 / Opening electromagnet |
| 32、碟簧 / Belleville spring | 41、半轴 / Haft-shaft |
| 33、绝缘拉杆 / Insulating pull rod | 42、手动分闸顶杆 / Manual opening pin |
| 34、传动拐臂 / Driving crank arm | 43、凸轮 / Cam |
| | 44、分合指示牌连板 / Connecting plate of ON/OFF indicator |

注：当断路器已处于合闸状态或选用闭锁装置而未使闭锁装置解锁及手车式断路器在推进推出过程中，均不能进行合闸操作。

Note: It is unable to conduct closing operation when the circuit breaker is in closing state, or when using the locking device while the locking device has not been unlocked, or during the propelling/withdrawing process of handcart type circuit breaker.

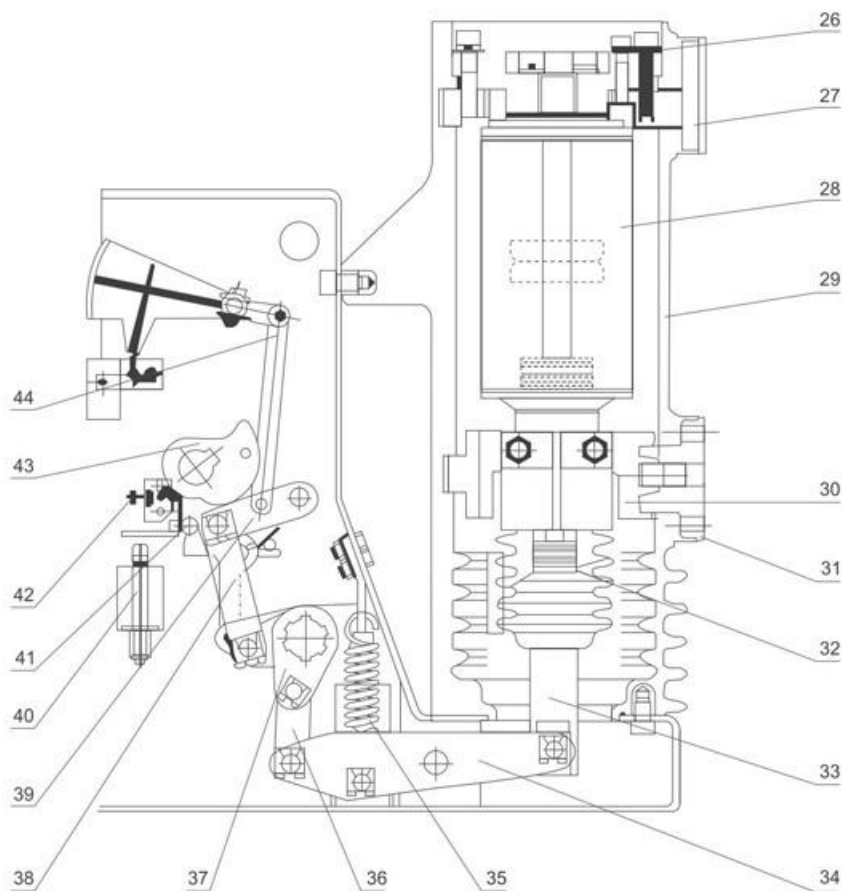
c.分闸 /Opening

既可按“分闸”按钮，也可靠接通外部电源使分闸脱扣电磁铁或过流脱扣电磁铁动作使合闸保持掣子38与半轴41解锁而实现分闸操作。由触头弹簧和分闸簧35储存的能量使灭弧室28动静触头分离。在分闸过程后段，由液压缓冲器吸收分闸过程剩余能量并限定分闸位置。由连杆44拉动合/分指示牌显示出“分”标记，同时拉动计数器，实现计数器计数，由传动连杆拉动主辅助开关切换。

Opening operation can be realized by pressing the Opening Button simply, or by putting through the external power supply and driving the opening tripping electromagnet or over-current tripping electromagnet to release the closing retaining detent 38 from half-shaft 41. The energy stored by contact spring and opening spring 35 enables the moving and static contacts of arc-extinguish chamber 28 to separate from each other. During the last stage of opening process, the hydraulic buffer would absorb the residual energy in opening, and restrict the opening position. The connecting rod 44 pulls the ON/OFF indicator to display "OFF", meanwhile, it drives the counter to count, and the driving rod actuates the main and auxiliary switches to switch over.



防误联锁 /Anti-misoperation interlocking

断路器主体部分设置在由环氧树脂采用APG工艺浇注而成的绝缘筒内，这种结构能有效地防止包括外力冲击、污秽环境等外部因素对真空灭弧室的影响。断路器主体安装在断路器框架后部，与操动机构连接一个整体。

Main body of circuit breaker is set in an insulating cylinder that is made of epoxy resin by means of APG casting, which protects the vacuum arc-extinguish chamber from impact of external forces, polluted environment, or other external factors. The main body of breaker is installed at the back of framework, forms into one-piece with the operating mechanism.

断路器能提供完善的防误操作功能。(参见图3、图4)

Circuit breaker provides perfect anti-misoperation function. (See Fig.3 and 4)

- 断路器合闸操作完成后，合闸联锁弯板1向下运动扣住合闸保持轴上的合闸弯板2，在断路器未分闸时将不能再次合闸。
 - 断路器在合闸结束后，如合闸信号未及时去除，断路器内部防跳控制回路将切断合闸回路防止多次重合闸。(可选)
 - 手车式断路器在未到试验位置或工作位置时，由联锁弯板3扣住合闸弯板2上的销4，同时切断合闸回路，防止断路器处于合闸状态进入负荷区。
 - 手车式断路器在工作位置或试验位置合闸后，由滚轮5压推进机构锁板6，手车将无法移动，防止在合闸状态推进或拉出负荷区。(图4)
 - 如果选用电气合闸闭锁，在未使闭锁装置解锁情况下阻止合闸操作。
- After the circuit breaker finishes the closing operation, the closing interlocking bending plate 1 moves downwards and catches the closing bending plate 2 on the closing retaining shaft, and it will not conduct closing again before the circuit breaker get into opening.
 - When the closing operation is finished, the anti-trip control circuit inside the circuit breaker would cut off the closing circuit to prevent reclosing if the closing signal has not been removed in time. (Optional)
 - When the handcart type circuit breaker has not reached the test or work position, the interlocking bending plate 3 would catch the pin 4 on the closing bending plate 2, meanwhile cut off the closing circuit, in order to prevent the circuit breaker entering into load area in closing state.
 - When the handcart type circuit breaker gets closing in work or test position, the idler wheel 5 will press the lock plate 6 of propelling mechanism, and the handcart could not move any more, in order to prevent pushing in or drawing out from the load area in closing state. (Fig.4)
 - When selecting electric closing locking, don't conduct closing operation when the locking device has not been unlocked.



图3/ Fig.3



图4/ Fig.4

注：合闸闭锁装置功率为2.7W，工作电压范围为0.65~1.1倍额定电压。

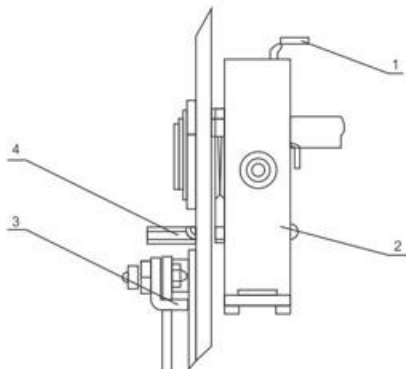
Note: power of closing locking device is 2.7W, operating voltage range is 0.65~1.1 times of rated voltage.

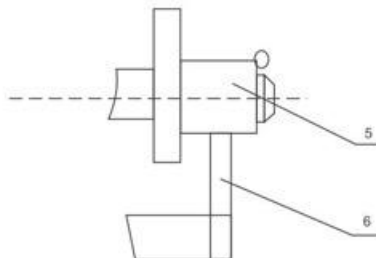

外型尺寸安装 [() 内为大电流尺寸]
Outline dimension and installation [data in () is dimension of heavy current]

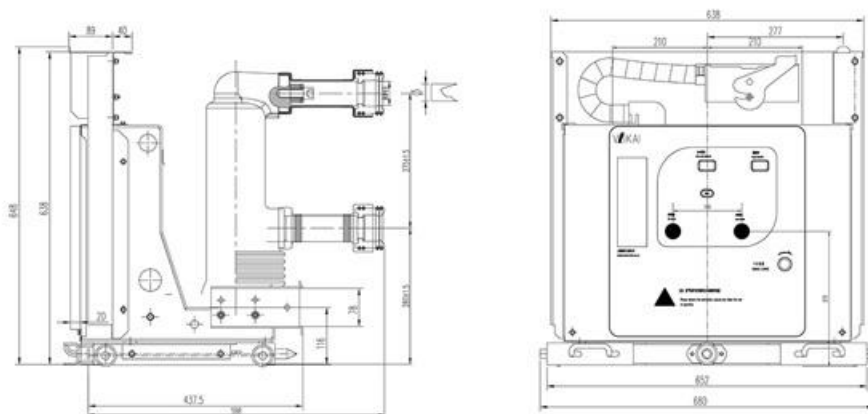

手车式 / Handcart type

额定电流(A) Rated current (A)	630	1250	1600	2000	2500, 3150, 4000
额定短路开断电流(KA) Rated short-circuit breaking current (kA)	20, 25, 31.5	20, 25, 31.5, 40	25, 31.5, 40	25, 31.5, 40	25, 31.5, 40
配合静触头尺寸(mm) Dim. of the static contact matched (mm)	Φ35	Φ49	Φ55	Φ79	Φ109

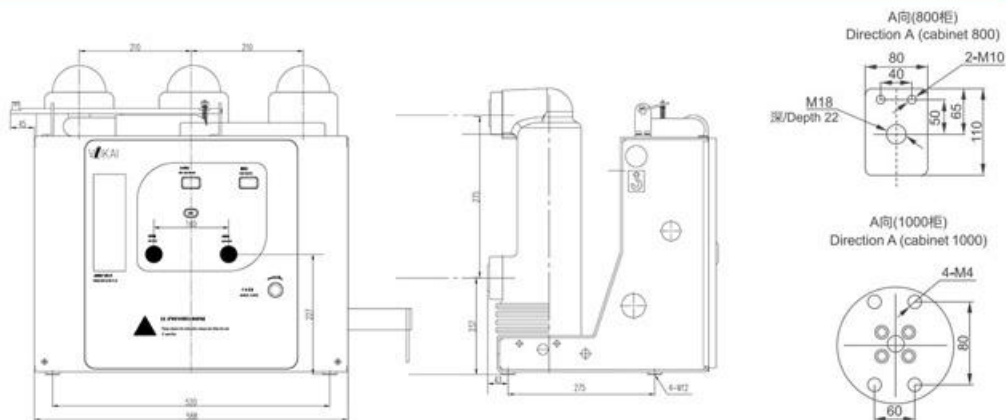

固定式 / Fixed type

额定电流(A) Rated current (A)	630	1250	1600	2000	2500, 3150, 4000
额定短路开断电流(KA) Rated short-circuit breaking current (kA)	20, 25, 31.5	20, 25, 31.5, 40	25, 31.5, 40	25, 31.5, 40	25, 31.5, 40

断路器内部电气接线原理图(手车式) Internal electric circuit diagram of circuit breaker (handcart type)

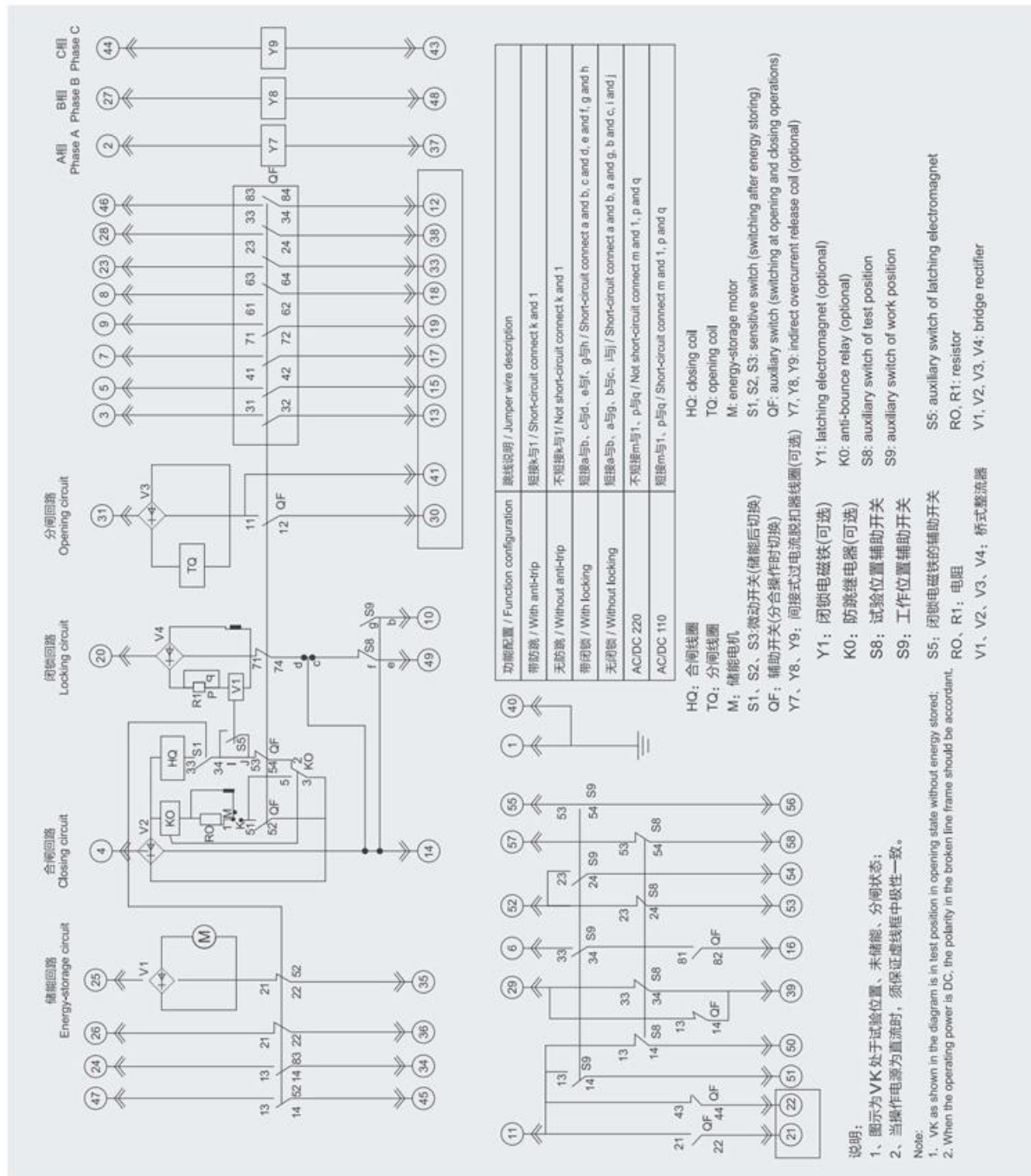

断路器内部电气接线原理图(固定式) Internal electric circuit diagram of circuit breaker (fixed type)

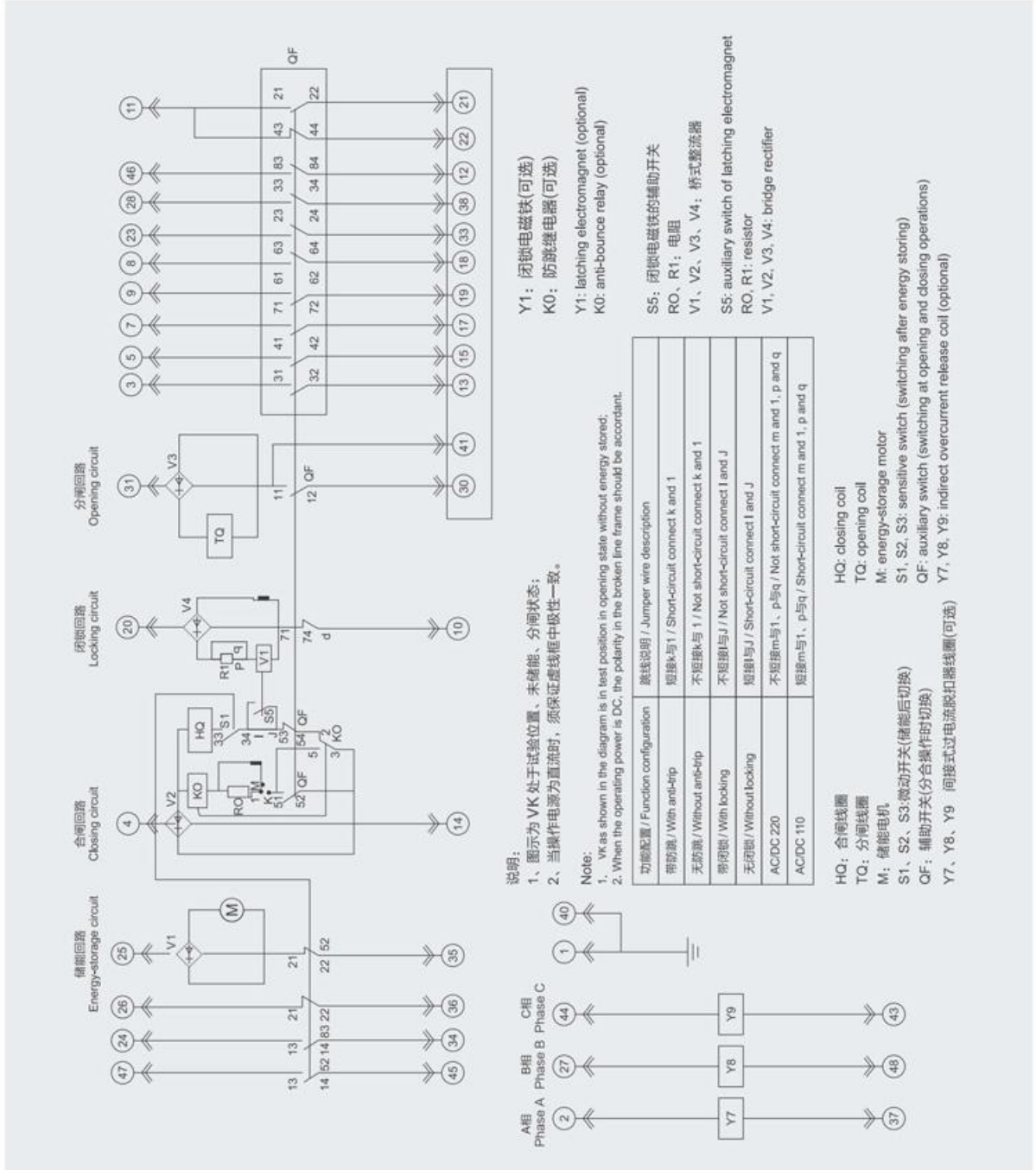

- 本手册所包含内容，本公司拥有最终解释权，更多详细资料敬请垂询
- 本公司工程技术人员将竭诚为您服务，图片与实物若有出入，请以实物为准
- 未经许可，禁止全部或部分复制
- 如有变更，届时恕不另行通知，衷心希望本手册能给您带来方便
- 产品不断研发、技术持续创新……

- The company reserves the right to the interpretation of all content in the manual. Please feel free to contact us for more details.
- Our technical staff shall provide best service to you sincerely. If the pictures is different from the real objects, Please refer to real object.
- Unauthorized Use, Prohibited to copy all or part of the information
- There's no prior notice if any change. Sincerely hope that this manual can bring convenience to you
- Products research and development, Continuous innovation of technology……

上海维凯电气有限公司

SHANGHAI VEIKAI ELECTRIC CO. LTD.

地址: 上海市嘉定区胜辛南路955号

邮编: 201802

E-mail: veikai@veikai.cn

<http://www.veikai.cn>

服务热线: 021-31139988



珍惜资源，善待环境
Take good care of the resources, Be kind to the environment!